

BORMANN *PRO*



BTS2105
036531

EN IT
EL BG
RO HR
HU



WWW.NIKOLAOUTOOLS.COM

SCAN ME



Necessary assembly tools / Strumenti di montaggio necessari / Απαραίτητα εργαλεία για την συναρμολόγηση του προϊόντος / Необходими инструменти за сглобяване / Unelte de asamblare necesare / Potreban alat za montažu/ Szükséges szerelőszerszámok

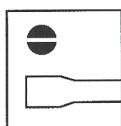

A

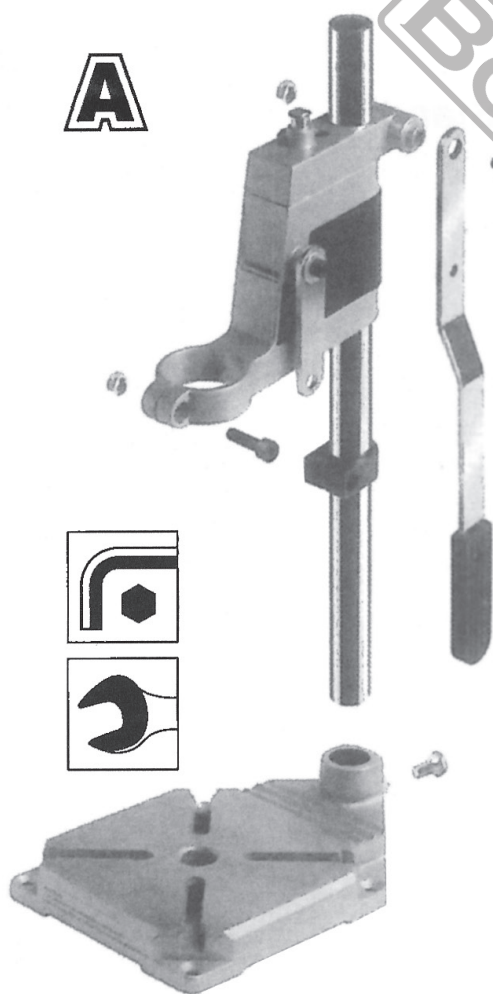

B

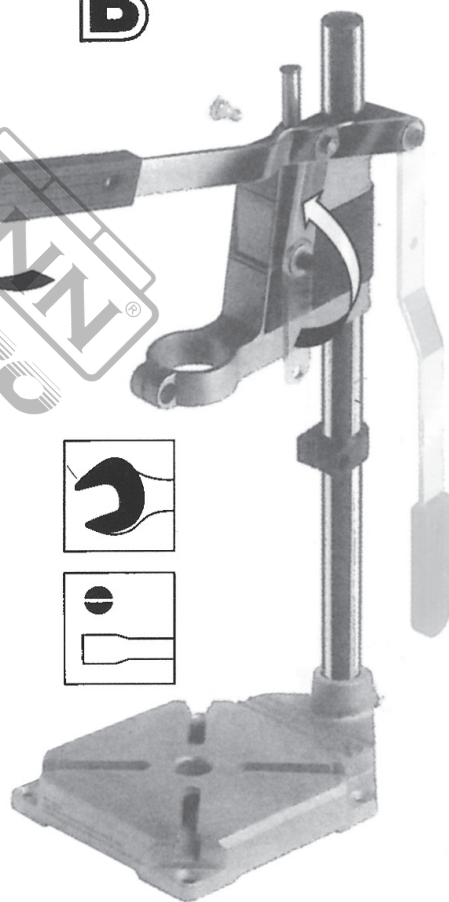

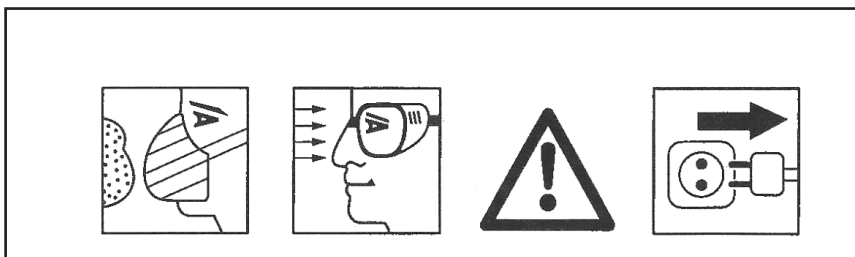
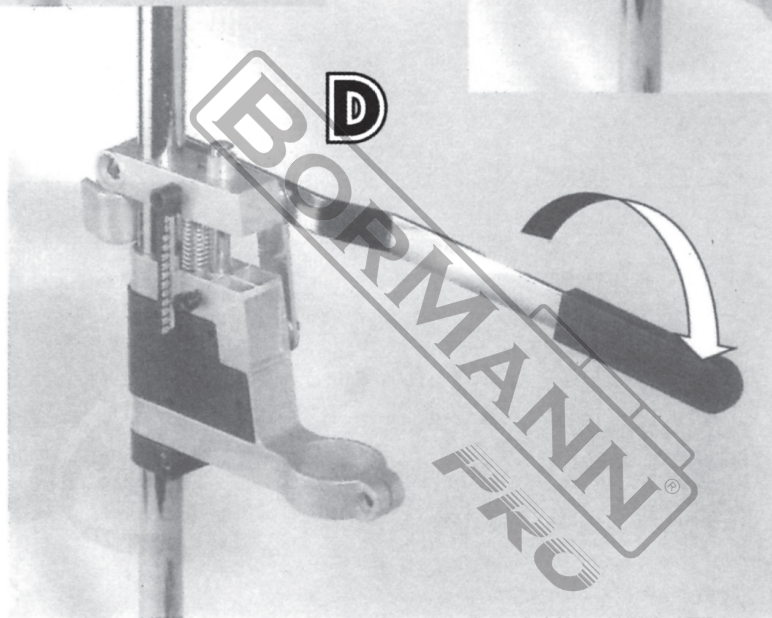
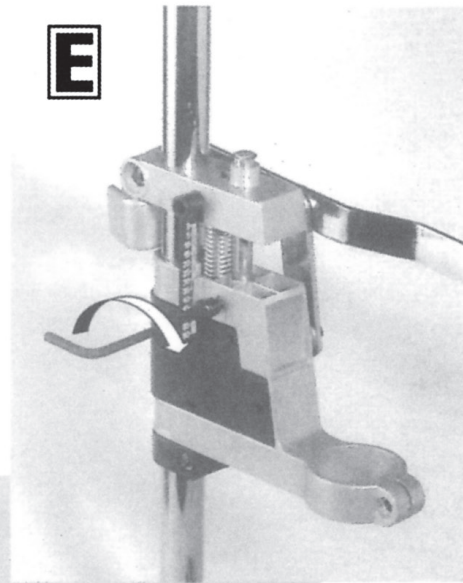
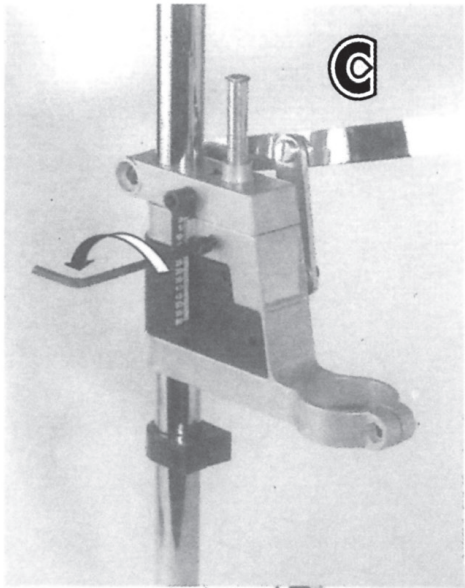

Adjustment of the depth stop: Alter gage to desired depth and tighten using the allen wrench / Regolazione dell'arresto di profondità: Regolare il calibro alla profondità desiderata e serrare con la chiave a brugola / Ρύθμιση του στοπ βάθους διάτρησης: Ρυθμίστε τον μηχανισμό στο επιθυμητό βάθος διάτρησης και σφίξτε χρησιμοποιώντας το κλειδί άλλεν / Регулиране на ограничителя на дълбочината: Преместете измервателния уред на желаната дълбочина и го затегнете с помощта на гаечен ключ / Reglarea opritorului de adâncime: Modificați calibrul la adâncimea dorită și strângeți-l cu ajutorul cheii Allen / Podešavanje graničnika dubine: Promijenite mjerač na željenu dubinu i zategnite imbus ključem/A mélységűtköző beállítása: Állítsa be a mérőeszközt a kívánt mélységre, és húzza meg az imbuszkulccsal.

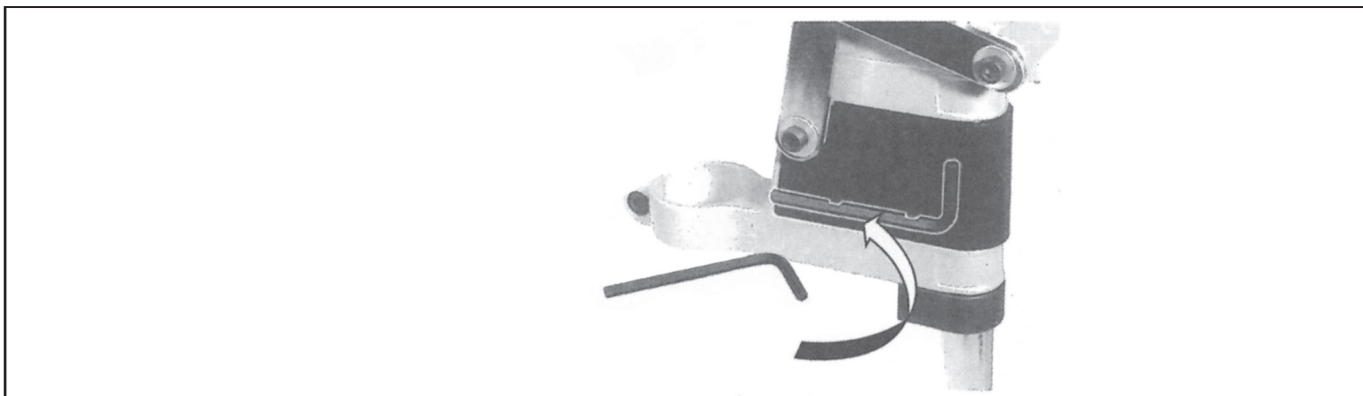

EN - IT

Technical data / Dati tecnici	
Dimensions / Dimensioni	225*160*500mm
Drilling depth / Profondità di foratura	60mm
Holding diameter / Diametro di tenuta	43mm

HU

Műszaki adatok	
Méreték	225*160*500mm
Fúrási mélység	60mm
Tartási átmérő	43mm

EL - BG

Τεχνικά χαρακτηριστικά / Технически данни	
Διαστάσεις / Размери	225*160*500mm
Βάθος διάτρησης / Дълбочина на пробиване	60mm
Διάμετρος συγκράτησης / Диаметър на захващане	43mm

RO - HR

Date tehnice / Tehnički podaci	
Dimensiuni / Dimenzije	225*160*500mm
Adâncimea de găurire / Dubina bušenja	60mm
Diametrul de fixare / Promjer držanja	43mm

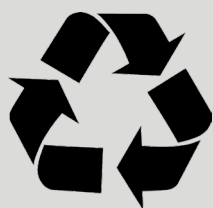

The instructions manual is also available in digital format on our website
www.nikolaoutools.com. Find it by entering the product code in the Search "Q" field.

Μπορείτε να βρείτε τις οδηγίες χρήσης και σε ηλεκτρονική μορφή μέσω της ιστοσελίδας μας
www.nikolaoutools.com. Αναζητήστε τις με τον κωδικό προϊόντος στο πεδίο Αναζήτηση "Q".